

American-Lincoln®

The Power Behind Clean

SC7730 Battery Powered Rider Sweeper/Scrubber



Introducing the SC7730 Sweeper/Scrubber 100 Years in the Making

American-Lincoln has drawn on its 100 years of engineering experience to make the new SC7730 Sweeper/Scrubber both the most reliable and the best at increasing your cleaning productivity. This machine easily fits into small areas, yet with its large capacity hopper and solution tanks can clean up to 70,000 square feet per hour effortlessly. If you are looking for high-quality, efficient cleaning equipment the SC7730 offers both.

Why Choose American-Lincoln?

- Quality cleaning equipment since 1903
- Introduced the first true “sweeper/scrubber”
- Manufacture largest scrubber in the world
- Best warranty in the industry

Innovative Key Features:

- Pulse-modulated brake system increases operator safety
- Patented Accu-Track™ squeegee system leaves a clean, dry floor even in the tightest turns
- Dynamic, regenerative electric drive motor enhances reliability
- Standard roll-on, roll-off battery changing system offers increased productivity



Dust control option provides dust-free sweeping before debris enters the scrubbing area.



Reliable rocker switches and a tilt steering wheel result in easy-to-use controls and low maintenance costs.



Large capacity batteries last for hours of cleaning and a quick and easy roll-on, roll-off battery changing system reduces downtime.

Battery compartment offers easy access for daily maintenance.

Deeply padded seat, power steering and tilt steering wheel provide top-of-the-line comfort.

Lifetime warranty on corrosion-proof, impact-resistant Polydur® solution and recovery tanks protects your investment.

Optional dust control system prevents stirring up even the finest dust while sweeping.

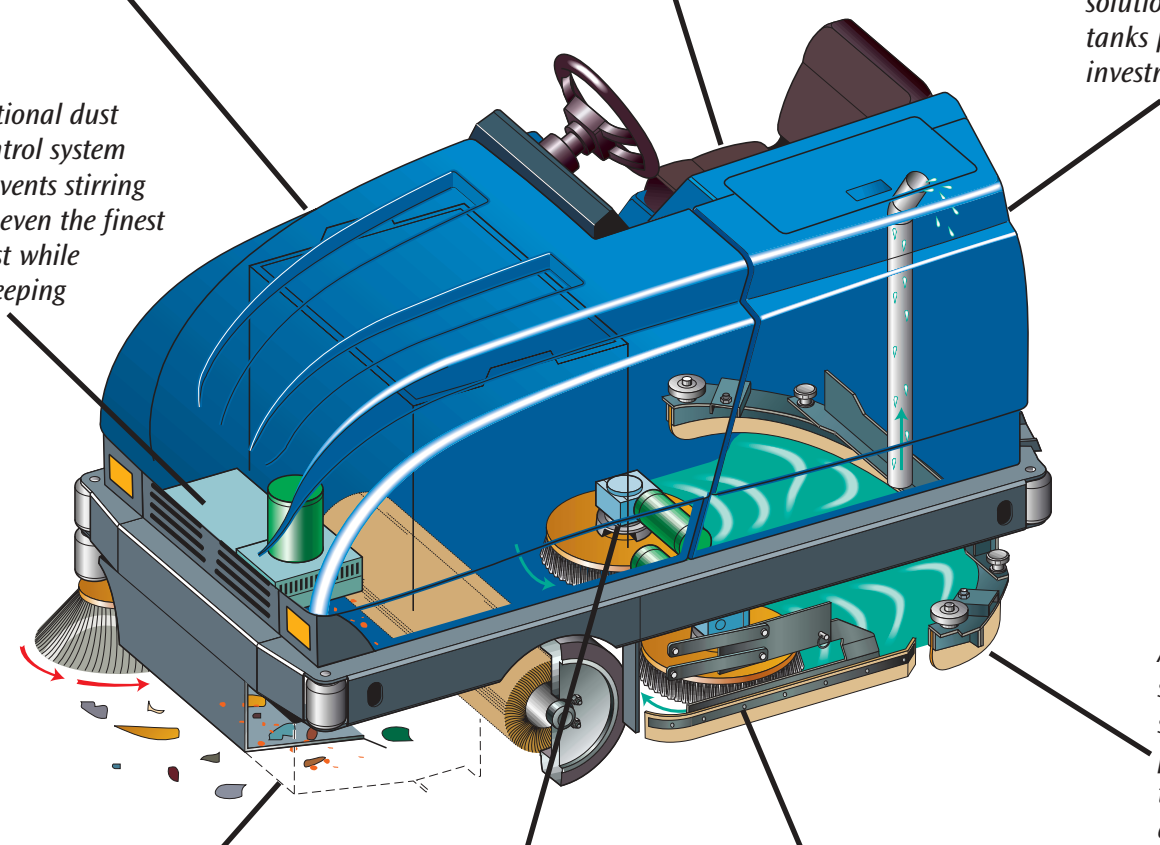

Independent dry sweeping system picks up dirt and debris before scrubbing.

Heavy-duty, high torque 1.7 h.p. brush drive motors aggressively clean the dirtiest floors.

Bristle type selection accommodates your cleaning needs.

Accu-Track™ squeegee provides superior water pickup even during the tightest turns and with no-tool squeegee change, maintenance is a snap.



Double-scrub disk brushes offer the most aggressive cleaning action with quick, no-tool changing in minutes.



Accu-Track™ squeegee provides superior water pickup even during the tightest turns and no-tool changing for easy maintenance.

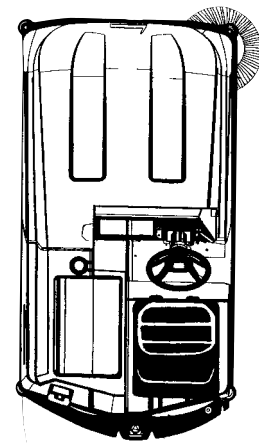

Sweeping and Scrubbing

Cleans up to 70,000 square feet per hour

SC7730

Compact Battery Sweeper/Scrubber

American-Lincoln®

The Power Behind Clean

Division of
ALTO®

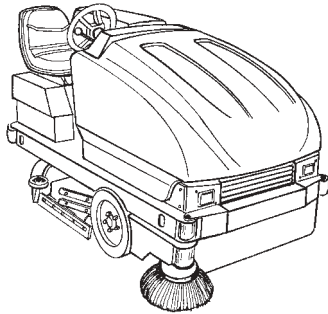

KEY FEATURES

- Two machines in one – sweeper and scrubber
- Powerful dust control system
- Pedal proportional braking
- Simple drain and clean-out system
- Roll-on, roll-off battery change system

SPECIFICATIONS

Scrub path	40 in. (101 cm.) or 46 in. (117 cm.)
Solution tank	55 gal. (170 l)
Recovery tank	55 gal. (170 l)
Hopper capacity	2.5 cu. ft. (71 l)
Brush sizes	2 20-in. (51 cm.) or 3 16-in. (40.6 cm.)
Brush speed	210 rpm
Transport speed	0 – 4.6 mph (0 – 7.4 kph)
Cleaning speed	0 – 2.7 mph (0 – 4.3 kph)
Brush motors	1.7 hp heavy-duty, angled gear motor
Vacuum motor (2)	1 h.p., 3-stage tangential discharge
Drive motor	2.7 h.p. (2,000 W)
Aisle U-turn	87 in. (221 cm.)
Size (LxWxH)	87 x 46 x 52 in. (221 x 116.8 x 132 cm.)
Weight (w/o batteries)	1,700 lbs. (765 kg.)

WHAT ENHANCES ITS PRODUCTIVITY?

- Powerful electric drive and power steering system
- Large solution/recovery tanks to stay on the floor longer between cleanups
- One-pass sweeping and scrubbing
- Solution and brushes turn off when machine is not moving

WHAT ADDS TO ITS DURABILITY?

- Sevcon traction drive controller
- Heavy gauge welded steel chassis
- Corrosion-proof Polydur® solution/recovery tanks
- Accu-Track™ break-away squeegee
- Durable corner roller bumpers for side protection

WHAT ARE ITS SAFETY FEATURES?

- Pulse-modulated brake system
- Dead man seat with traction lockout
- Controlled directional drive
- Better handling with rack and pinion power steering
- Excellent front and rear view for operator

American-Lincoln

1100 Haskins Rd
Bowling Green, OH 43402
www.americanlincoln.com

DISTRIBUTED BY:



Customer Service: 1-800-331-7692
Fax Orders to: 1-877-877-2586
Technical Service: 1-800-331-7691