

metro 1103

WORKING SCHEME

- 1- BRUSHES
- 2- SOLUTION TANK
- 3- RECOVERY TANK
- 4- VACUUM MOTORS
- 5- BATTERY
- 6- SQUEEGEE
- 7- SWEEPING SYSTEM (OPTIONAL)

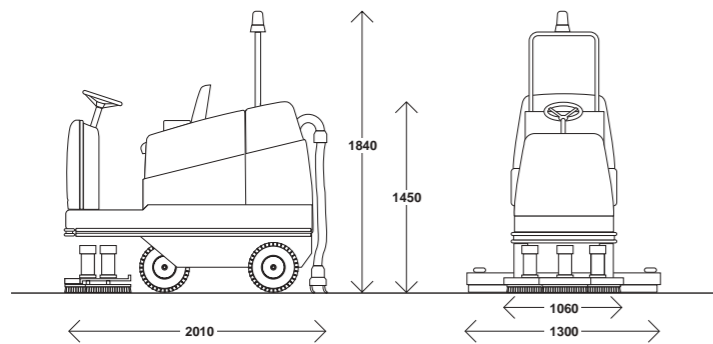
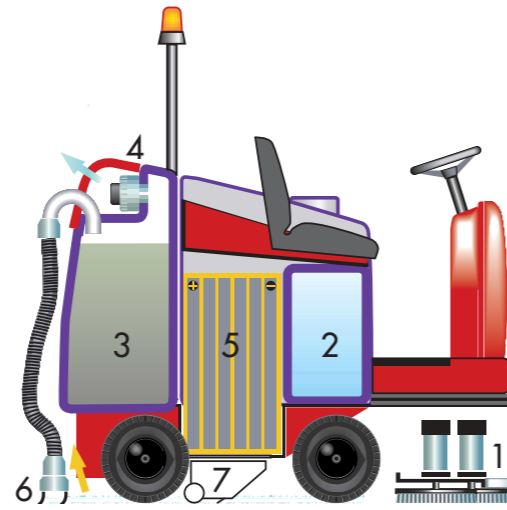

Max cleaning capacity	m ² /h	5350
Scrubbing width	mm	1060
Drying width	mm	1300
Front brushes	n.	3
Solution tank	lt	250
Recovery tank	lt	280
Max battery capacity	V/A	36/480
Traction motors	n/V/W	2/36/500
Brush motors	n/V/W	3/36/500
Vacuum motors	n/V/W	2/36/800
Wheels	ø mm	375
Machine Weight (empty)	Kg	480
Battery weight	Kg	520
Sweeping system (optional):		
Sweeping width	mm	650
Brush diameter	mm	170
Brush rotation	giri/m	430
Brush motor	V/W	36/200
Hopper	lt	12

RCM reserves the right to change the data based on technical modification.



RCM S.p.A. Via Tiraboschi, 4 - 41041 Casinalbo - MODENA ITALY - Tel. + 39 - 059 515311 fax + 39 - 059 510783
www.rcm.it - E-mail : inforcm@rcm.it



metro 1103



metro 1103 is a scrubber/drier for large areas. It is powered by a 36 V battery and with a cleaning width of 1070 mm. Strong and simple with easy maintenance, the large diameter wheels give excellent traction on slippery surfaces and slopes. Coupled with the low centre of gravity by placing the large traction battery low in the chassis gives the **metro 1103** stability and comfort.

metro 1103 offers the max endurance possible in this class: 205 litres for the solution tank, 280 litres the recovery tank, 36 v and 480 A batteries.

With the front brushes clean also in the corners, dries completely and also picks up small debris.



SWEEPERS - SCRUBBERS

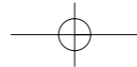

Discharge pipe

Squeegee with rubbers useable on the 4 sides



Dry the wet trail also with the minimum turning radius

Safe drive

The special traction system on side wheels with double electronic control permit to drive the **metro 1103** in a safe and precise way also on very slippery floor and on strong slope. Two electronic control (one for each wheel) distribute the power to the respective traction motors on the base of the steering wheel rotation. At any time with every turning radius the drive is safe and precise.

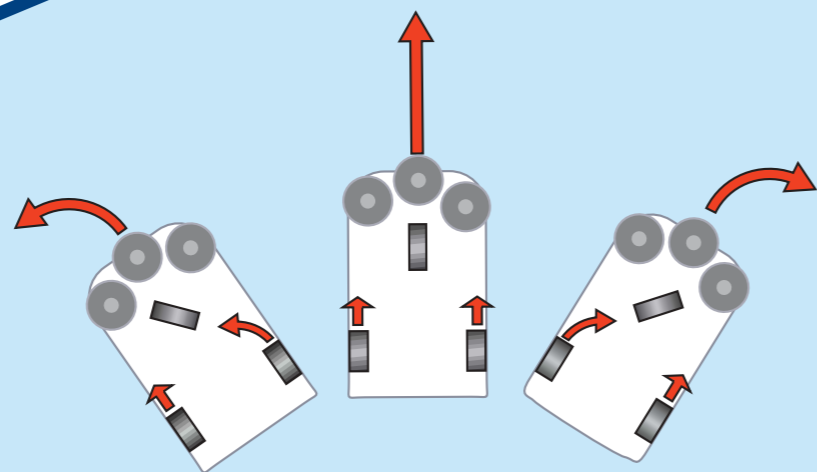

Sweeping system

Picks up the solid debris by sweeping, washing and drying. Built completely in stainless steel, placed in the middle of the machine behind the washing brushes, silent and with very low energy use. The cylindrical brush is free to follow the floor undulations without any regulation.



V Squeegee of easy regulation and rubbers useful on the 4 sides and replaceable without any tools (see photo).



Double vacuum motor to dry perfectly also loose floor or with worn out squeegee



Comfortable entry to the battery and to the connection for the battery charger.



The rear traction allows it to climb over steep and wet slope surfaces.



Big diameter wheels for better traction and max comfort.



The pressure on the brushes is controlled and kept steady electronically.

